



Compressor
Voltage Code : XC

FH4525Y-XC

High Temp. Commercial (HP)

220 - 240V 1~ 50 Hz

R134a / R513A

FH4525Y-XC3A

Conditions	Frequency	Nominal Cooling Capacity		Sound Power ISO3745 / ISO 3743-1
		Watts	BTU/h	
EN12900 / R134a	50 Hz	5389	18375	70 dBA
EN12900 / R513A	50 Hz	5485	18703	70 dBA

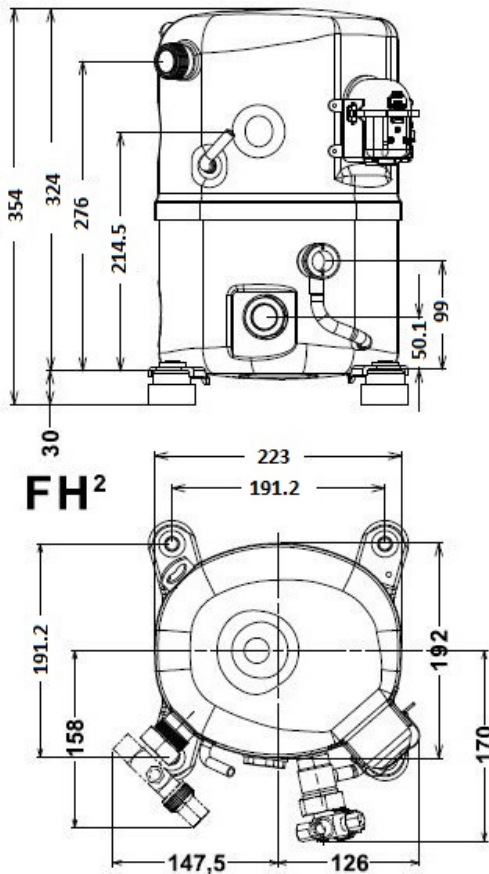

Displacement (cc)	63
Net Weight (Kg)	30.0
Oil Quantity (cc)	1140.0
Oil Type	Polyolester
Expansion Device	Capillary_Tube/Expansion_Valve
Cooling	Fan
Main Winding (Ohm)	1.31
Start Winding (Ohm)	3.8
Current	
RLA (A)	9.5
MCC (A)	14
LRA (A)	52
Electrical Equipment	CSR
Overload	Interne
Start Capacitor	88 µF / 330 V
Run Capacitor	35 µF / 400 V
Potential Relay	RVA4G**
Pick Up	180/195V
Drop Out	40/105V
Refrigerating connection for	
Suction Tube	15.9 (5/8")
Discharge Tube	12.7 (1/2")
Process Tube	6.35 (1/4")

* EN12900 : T°Cond. 50.0°C / T°Evap. 5.0°C / T°Return gas temp.. 20.0°C
T°Subcooling. 0.0K

Certificates :



Note : Tecumseh reserves the right to change information contained in this document without notification.



Tecumseh

FH4525Y-XC	Tension XC : 220 - 240V 1~ 50 Hz
-------------------	---

Les performances sont données dans les **conditions EN12900** :
 Condition Mid
 The performance data are in **EN12900 conditions** :
 Mid Condition

Gaz aspirés : 20.0 °C
 Sous refroidissement : 0.0 K
 Return gas : 20.0 °C
 Subcooling : 0.0 K

© 2022 Tecumseh Products Company
All rights reserved

50 Hz R134a

N°User-355

4 T condensation	5 T évaporation	(°C)	-25	-20	-15	-10	-5	0	5	10	15
30	1 P frigorifique	(Watt)	1456	2101	2871	3788	4870	6141	7619	9325	11282
	2 P absorbée	(W)	847	967	1081	1189	1292	1389	1483	1571	1656
	3 I absorbée	(A)	4.05	4.70	5.30	5.86	6.39	6.87	7.31	7.71	8.07
40	1 P frigorifique	(Watt)		1611	2297	3105	4056	5170	6469	7971	9700
	2 P absorbée	(W)		986	1135	1280	1420	1557	1692	1823	1951
	3 I absorbée	(A)		4.60	5.38	6.13	6.83	7.50	8.12	8.71	9.25
50	1 P frigorifique	(Watt)			1771	2477	3301	4265	5389	6693	8200
	2 P absorbée	(W)			1155	1341	1525	1707	1888	2067	2245
	3 I absorbée	(A)			5.44	6.36	7.25	8.10	8.91	9.67	10.4
60	1 P frigorifique	(Watt)				1914	2617	3436	4392	5504	6794
	2 P absorbée	(W)				1378	1611	1843	2075	2307	2540
	3 I absorbée	(A)				6.57	7.64	8.67	9.66	10.6	11.5

50 Hz R513A

N°User-356

4 T condensation	5 T évaporation	(°C)	-25	-20	-15	-10	-5	0	5	10	15
30	1 P frigorifique	(Watt)	1681	2380	3187	4120	5193	6423	7825	9415	11210
	2 P absorbée	(W)	942	1061	1170	1273	1376	1482	1596	1723	1867
	3 I absorbée	(A)	4.51	5.16	5.74	6.28	6.80	7.32	7.87	8.45	9.10
40	1 P frigorifique	(Watt)		1785	2507	3339	4297	5395	6652	8081	9700
	2 P absorbée	(W)		1072	1222	1364	1503	1643	1789	1945	2116
	3 I absorbée	(A)		5.00	5.80	6.53	7.23	7.91	8.59	9.29	10.0
50	1 P frigorifique	(Watt)			1890	2607	3435	4388	5485	6739	8168
	2 P absorbée	(W)			1231	1422	1607	1791	1978	2174	2383
	3 I absorbée	(A)			5.79	6.75	7.64	8.50	9.33	10.2	11.0
60	1 P frigorifique	(Watt)				1971	2655	3449	4372	5437	6661
	2 P absorbée	(W)				1447	1689	1927	2167	2412	2668
	3 I absorbée	(A)				6.90	8.01	9.07	10.1	11.1	12.1

1 = cooling capacity 2 = power input 3 = current 4 = condensing temperature 5 = evaporating temperature

Nota : Tecumseh se réserve le droit de modifier les informations contenues dans ce document sans préavis.

Note : Tecumseh reserves the right to change information contained in this document without notification.