

Input data

Refrigerant	R404A	
Reference temperature	Dew point temperature	
Calculation mode	Refrigeration / Air Cond.	
Operating mode	Subcritical	
Power supply	400/3/50	
Ambient temperature	°C	35
Liquid subcooling	K	3
Liquid temperature	°C	39,91
Evaporating temperature	°C	-25
Evaporating pressure	bar	2,5
Suction gas superheating	K	10
Useful fraction of superheating	%	100

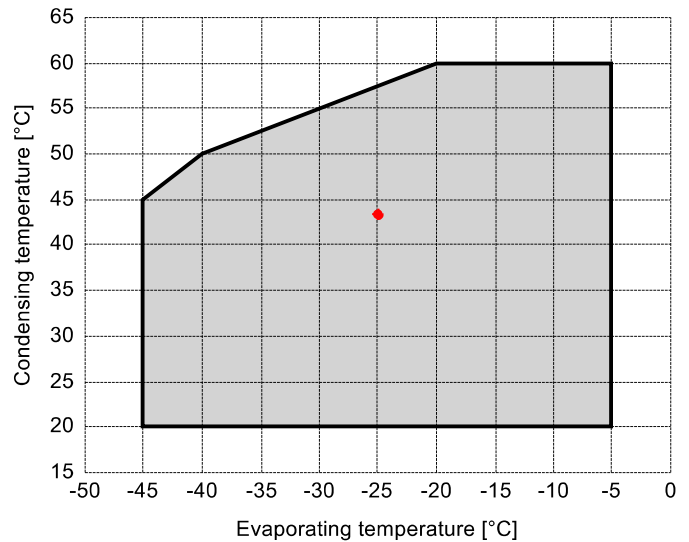

Output data

Compressor :	LB2-S1052-3Y-2T	
Number of compressors :	FSx1	
Refrigerating capacity	kW	13,236
Condensing temperature (dew point)	°C	43,25
Evaporator capacity	kW	13,236
Power input (with fan)	W	10136
Condenser capacity, theor.	kW	21,872
Current	A	15
COP/EER (with fan)	W/W	1,31
Mass flow	kg/h	474
Operating frequency	Hz	50
Connection	-	PWS
Operating mode	-	100%
Discharge temperature	°C	78,11
Ratio (%)	%	100,0%
Note	-	
Oil flow	l/min	-
Heat Exchanged (oil Cooler)	kW	-
Oil Temp. at Oil Cooler Outlet	°C	-
Certified by	-	Frascold

Compliant with EU Ecodesign Directive 2009/125/EC - Regulation EU 2015/1095.

Certified by:

- Frascold Data



Legend:

- *ref: At conditions according to EN12900
- Suction gas temperature = 20 °C
- Liquid subcooling = 0 K

All data subject to change without notice

Model: LB2-S1052-3Y-2T

Refrigerant: R404A

Power supply: 400/3/50 PWS

Dimensions:

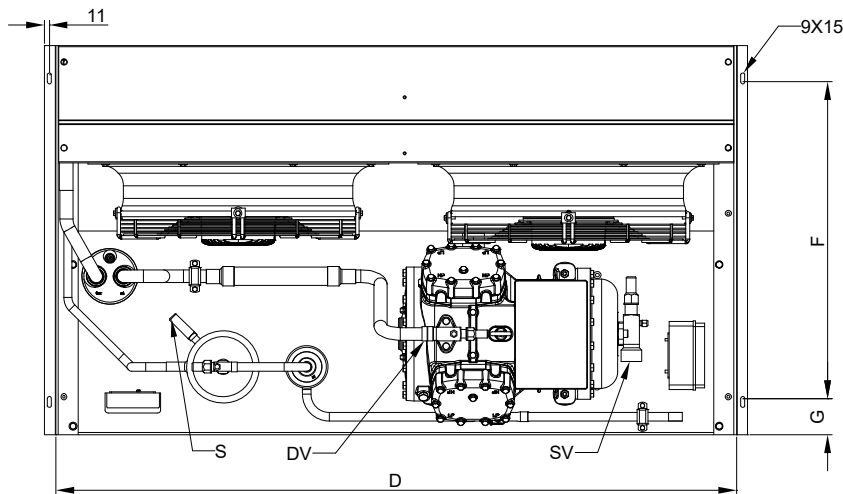
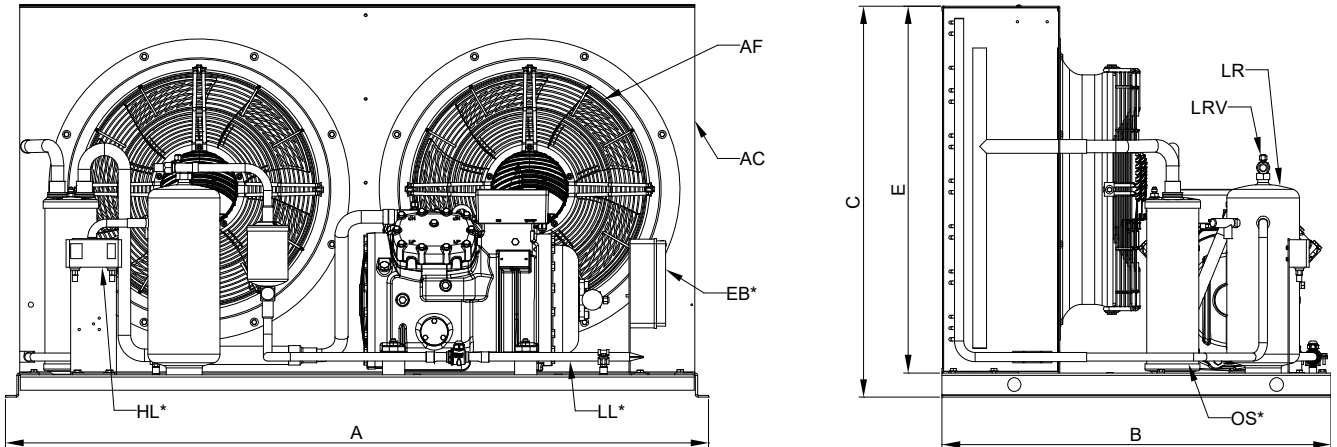

Legend:

SV: Suction Valve	35 mm - 1 3/8" in	S: Safety Valve	
LRV: Liquid valve	19 mm - 3/4" in	AC: Condenser	AC Type
A: Length	1556 mm	AF: Fan motor	
B: Width	860 mm	DV: Discharge valve	
C: Height	867 mm	LR: Liquid receiver	
A: Length (with housing)	1556 mm	OS*: Oil separator	
B: Width (with housing)	884 mm	EB*: Electric box	
C: Height (with housing)	888 mm	HL*: High/Low pressure switch	
D: Base length	1504 mm	H*: High pressure switch	
E: Condenser Height	813 mm	LL*: Liquid line	
F: Base mounting	700 mm	*Package	
G: Base mounting	80 mm		

All data subject to change without notice