

NL7.3MF

Standard Compressor

R134a

220-240V 50Hz & 208-230V 60Hz

General

| | |
|-----------------------|-------------------------------|
| Code number | 105G6772 |
| Approvals | EN 60335-2-34, UL984/CSA 22.2 |
| Compressors on pallet | 80 |

Application

| Application | MBP | | | |
|--|-----|-----------|------------|--|
| | Hz | 50 | 60 | |
| Frequency | Hz | 50 | 60 | |
| Evaporating temperature | °C | -20 to 10 | -25 to 7.2 | |
| Voltage range | V | 187 - 254 | 198 - 254 | |
| Max. condensing temperature continuous (short) | °C | 60 (70) | 60 (70) | |
| Max. winding temperature continuous (short) | °C | 125 (135) | 125 (135) | |

Cooling requirements at max. ambient temperature

| Frequency | Hz | 50 | | | 60 | | |
|-----------|----|-----|----------------|-----|-----|----------------|-----|
| | | LBP | MBP | HBP | LBP | MBP | HBP |
| 32°C | | - | F ₁ | - | - | F ₁ | - |
| 38°C | | - | F ₁ | - | - | F ₁ | - |
| 43°C | | - | F ₁ | - | - | F ₁ | - |

Remarks on application: F₂ for 230-240V 50Hz nominal below -12°C evaporating temperature
CSIR strongly recommended for 60Hz

Motor

| Motor type | RSIR/CSIR | | |
|---|-----------|------|------|
| LRA (rated after 4 sec. UL984), HST LST | A | 11.3 | 8.8 |
| Cut in Current, HST LST | A | 11.3 | 12.9 |
| Resistance, main start winding (25°C) | Ω | 8.3 | 17.0 |

Design

| | | |
|-------------------------------------|-----------------|-------------------|
| Displacement | cm ³ | 7.27 |
| Oil quantity (type) | cm ³ | 320 (polyolester) |
| Maximum refrigerant charge | g | 600 |
| Free gas volume in compressor | cm ³ | 2360 |
| Weight without electrical equipment | kg | 10.5 |

Dimensions

| | | |
|----------------------|--------------------------|---------------------------|
| Height | A | 197 |
| | B | 191 |
| | B1 | - |
| | B2 | - |
| Suction connector | location/I.D. mm angle | C 8.2 15° |
| | material comment | Cu-plated steel Al caps |
| Process connector | location/I.D. mm angle | D 6.2 25° |
| | material comment | Cu-plated steel Al caps |
| Discharge connector | location/I.D. mm angle | E 6.2 35° |
| | material comment | Cu-plated steel Al caps |
| Oil cooler connector | location/I.D. mm angle | F - |
| | material comment | - |
| Connector tolerance | I.D. mm | ±0.09 |
| Remarks: | | |

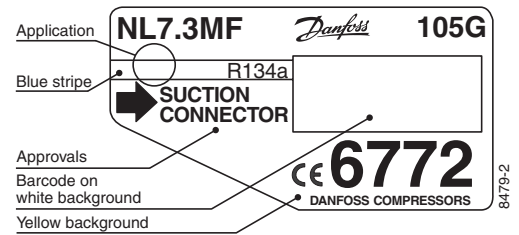

- S = Static cooling normally sufficient
- O = Oil cooling
- F₁ = Fan cooling 1.5 m/s
(compressor compartment temperature equal to ambient temperature)
- F₂ = Fan cooling 3.0 m/s necessary
- SG = Suction gas cooling normally sufficient
- = not applicable in this area

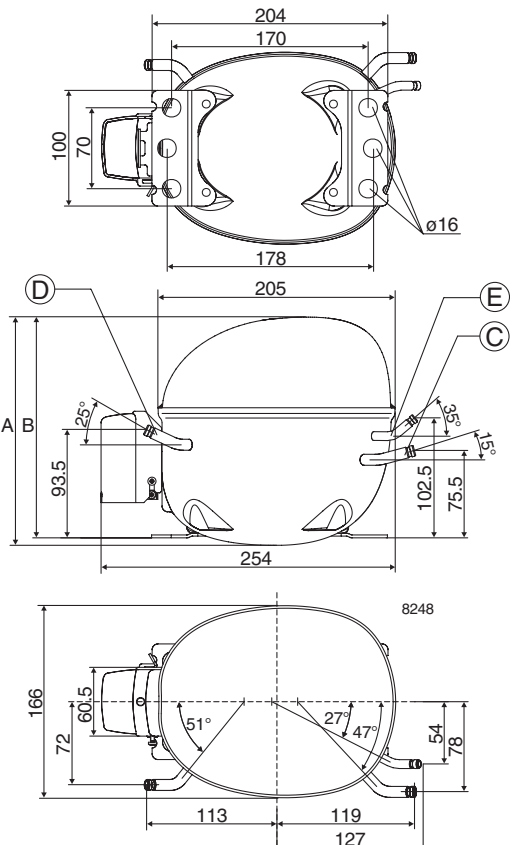

EN 12900 Household (CECOMAF) 220V, 50Hz, fan cooling F₁

| | | | | | | | | | | | | | | | | | |
|--------------------|-----|-----|-----|-----|-----|-------|------|------|------|------|------|------|------|------|------|----|----|
| Evap. temp. in °C | -45 | -40 | -35 | -30 | -25 | -23.3 | -20 | -15 | -10 | -6.7 | -5 | 0 | 5 | 7.2 | 10 | 15 | 20 |
| Capacity in W | | | | | | | 179 | 236 | 304 | 356 | 385 | 480 | 591 | 645 | 719 | | |
| Power cons. in W | | | | | | | 181 | 204 | 227 | 242 | 250 | 274 | 298 | 310 | 325 | | |
| Current cons. in A | | | | | | | 1.57 | 1.61 | 1.67 | 1.71 | 1.74 | 1.82 | 1.91 | 1.96 | 2.02 | | |
| COP in W/W | | | | | | | 0.99 | 1.16 | 1.34 | 1.47 | 1.54 | 1.75 | 1.98 | 2.08 | 2.21 | | |

EN 12900 Household (CECOMAF) 220V, 60Hz, fan cooling F₁, preliminary data

| | | | | | | | | | | | | | | | | | |
|--------------------|-----|-----|-----|-----|-----|-------|-----|-----|------|------|----|------|---|------|----|----|----|
| Evap. temp. in °C | -45 | -40 | -35 | -30 | -25 | -23.3 | -20 | -15 | -10 | -6.7 | -5 | 0 | 5 | 7.2 | 10 | 15 | 20 |
| Capacity in W | | | | | | | | | 370 | 423 | | 585 | | 769 | | | |
| Power cons. in W | | | | | | | | | 277 | 298 | | 356 | | 420 | | | |
| Current cons. in A | | | | | | | | | 1.60 | 1.73 | | 1.95 | | 2.22 | | | |
| COP in W/W | | | | | | | | | 1.34 | 1.42 | | 1.64 | | 1.83 | | | |

ASHRAE MBP 220V, 50Hz, fan cooling F₁

| | | | | | | | | | | | | | | | | | |
|--------------------|-----|-----|-----|-----|-----|-------|------|------|------|------|------|------|------|------|------|----|----|
| Evap. temp. in °C | -45 | -40 | -35 | -30 | -25 | -23.3 | -20 | -15 | -10 | -6.7 | -5 | 0 | 5 | 7.2 | 10 | 15 | 20 |
| Capacity in W | | | | | | | 197 | 260 | 335 | 392 | 424 | 528 | 651 | 710 | 792 | | |
| Power cons. in W | | | | | | | 181 | 204 | 226 | 241 | 249 | 273 | 297 | 308 | 323 | | |
| Current cons. in A | | | | | | | 1.57 | 1.61 | 1.67 | 1.71 | 1.74 | 1.82 | 1.91 | 1.95 | 2.02 | | |
| COP in W/W | | | | | | | 1.09 | 1.28 | 1.48 | 1.62 | 1.70 | 1.94 | 2.19 | 2.30 | 2.45 | | |

ASHRAE MBP 220V, 60Hz, fan cooling F₁, preliminary data

| | | | | | | | | | | | | | | | | | |
|--------------------|-----|-----|-----|-----|-----|-------|-----|-----|-----|------|----|---|---|------|----|----|----|
| Evap. temp. in °C | -45 | -40 | -35 | -30 | -25 | -23.3 | -20 | -15 | -10 | -6.7 | -5 | 0 | 5 | 7.2 | 10 | 15 | 20 |
| Capacity in W | | | | | | | | | | 466 | | | | 845 | | | |
| Power cons. in W | | | | | | | | | | 297 | | | | 420 | | | |
| Current cons. in A | | | | | | | | | | 1.73 | | | | 2.22 | | | |
| COP in W/W | | | | | | | | | | 1.57 | | | | 2.01 | | | |

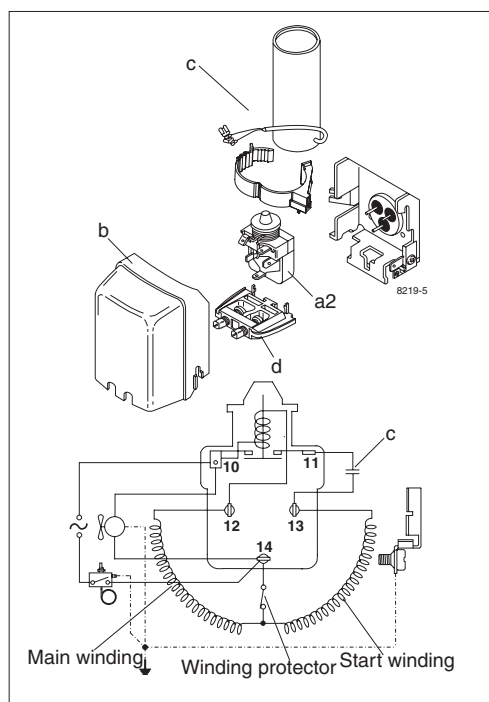
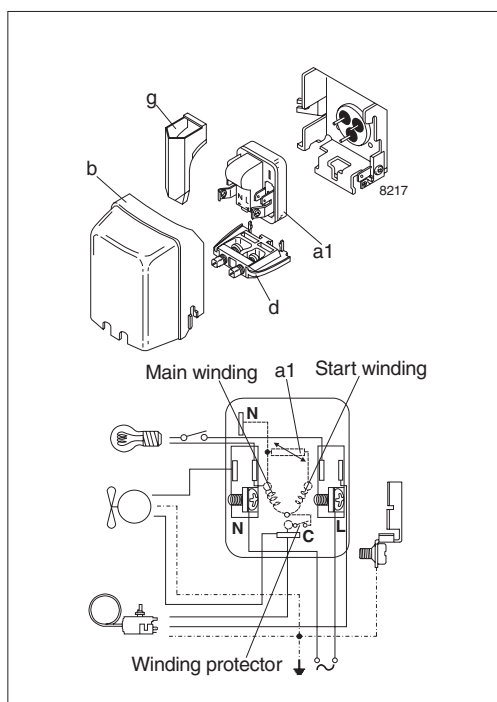

| Accessories for | NL7.3MF | Figure | Code number |
|---------------------------|-------------------------|--------|-------------|
| PTC starting device | 6.3 mm spade connectors | a1 | 103N0011 |
| | 4.8 mm spade connectors | | 103N0018 |
| Starting relay | 6.3 mm spade connectors | a2 | 117U6016 |
| Cover (UL-approved) | | b | 103N2011 |
| Start. capacitor 80 µF | 6.3 mm spade connectors | c | 117U5015 |
| Cord relief | | d | 103N1010 |
| Protection screen for PTC | | g | 103N0476 |

| Test conditions | EN 12900/CECOMAF | ASHRAE |
|-------------------------|------------------|--------|
| Condensing temperature | 55°C | 54.4°C |
| Ambient temperature | 32°C | 35°C |
| Suction gas temperature | 32°C | 35°C |
| Liquid temperature | no subcooling | 46.1°C |

| Mounting accessories | Code number |
|-------------------------------|-------------|
| Bolt joint for one compressor | 118-1917 |
| Bolt joint in quantities | 118-1918 |
| Snap-on in quantities | 118-1919 |

Danfoss can accept no responsibility for possible errors in catalogues, brochures and other printed material. Danfoss reserves the right to alter its products without notice. This also applies to products already on order provided that such alterations can be made without subsequential changes being necessary in specifications already agreed. All trademarks in this material are property of the respective companies. Danfoss and the Danfoss logotype are trademarks of Danfoss A/S. All rights reserved.